

axl 30 DIY Drone Kit

User Manual

V1.0 | 25.02

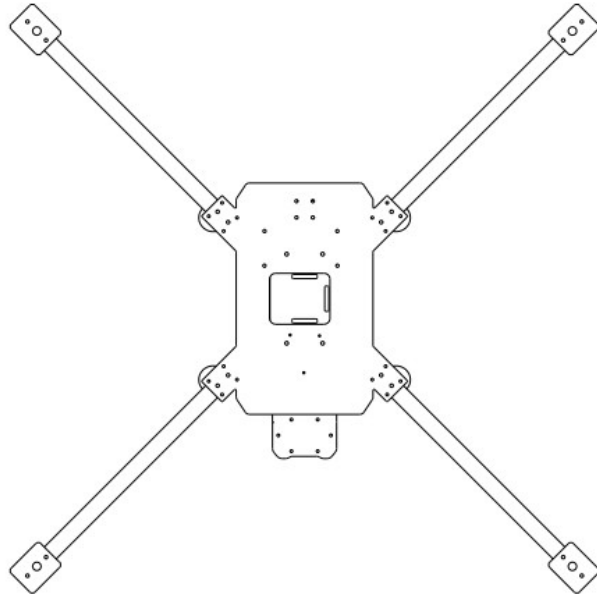

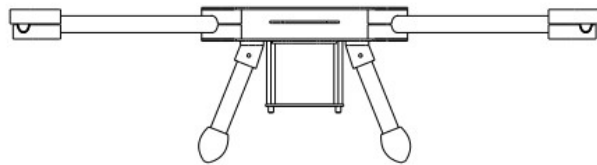

This document is the intellectual property of axldrone India Pvt. Ltd. and is protected under applicable copyright laws. Unless expressly authorized by axldrone, you may not reproduce, distribute, transmit, or sell this document or any portion of its contents in any form.

This document is intended solely for the purpose of guiding users in the proper operation of axldrone products. It must not be used for any other purposes, commercial or otherwise, without prior written consent from axldrone India Pvt. Ltd.

Table of Contents

Overview	1
What's in the Box	2
Tools You'll Need	5
Step By Step Assembly.....	6
Specifications	12
Key Features.....	12
Storage & Maintenance.....	13
Safety Guidelines	13

Overview

Welcome to your DIY Drone Kit!

The axl 30 DIY Drone Kit is a lightweight, modular quadcopter airframe designed for hobbyists, educators, and researchers. Constructed from carbon fiber and weighing approximately 500g, it offers a compact footprint (509 x 509 x 147 mm) for agile, responsive flight. The airframe is engineered for durability and ease of assembly, positioning it as an ideal choice for both beginners and experienced drone builders.



Beyond its structural qualities, the kit emphasizes a hands-on assembly experience. It includes all essential components, along with 3D-printed parts that simplify replacements and upgrades. This approach keeps costs down and maintenance accessible—replacing damaged components doesn't require reordering the entire kit, just the affected part.





The axl 30 airframe is versatile enough to support a variety of applications—from FPV flying and aerial photography to surveying, mapping, surveillance, and exploration. Its smart design encourages customization tailored to specific use cases, making it a flexible platform for both educational and professional environments.

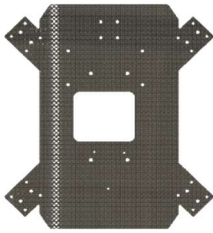
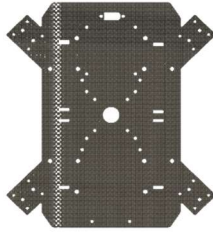

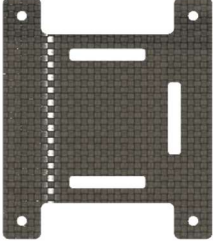

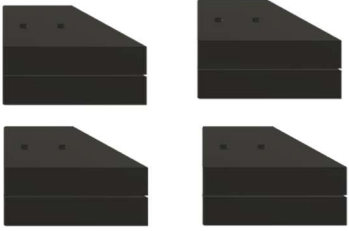
Proudly made in India under the Make-in-India initiative, the kit focuses on combining performance with affordability. With its carbon fiber construction, modular design, comprehensive component set, and locally sourced materials, the axl 30 strikes a balance between durability, ease of use, and cost-effectiveness—making it an excellent entry point into drone building and experimentation.

This manual will guide you through the components, assembly, setup of your drone. Perfect for learning, experimentation, and customization.

What's in the Box

Component	Quantity	Image
Carbon fiber frame panel (top)	1	
Carbon fiber frame panel (bottom)	1	
Carbon fiber Battery Mount	1	
Carbon fiber FC Mount	1	

<p>Arm Mount</p>	<p>4 Set</p>	
<p>Arm (16mm Carbon Fiber tube)</p>	<p>4</p>	
<p>Aluminum Standoff/Spacer</p>	<p>4</p>	
<p>Motor Mount</p>	<p>4 Set</p>	

<p>Leg Mount</p>	<p>4</p>	
<p>Leg (16mm Carbon Fiber tube)</p>	<p>4</p>	
<p>Leg Foot</p>	<p>4</p>	
<p>Camera Mount</p>	<p>1</p>	

Screws, Nuts		
Component		Quantity
Arm Mount	M3×40	8
	M3 Nut	8
Motor Mount	M3×35	16
Leg Mount	M3×10	8
	M3 Nut	8
Camera Mount	M3×10	2
	M3 Nut	2
Battery Tray	M3×6	8
	10 mm Spacer	4
Flight Controller Tray	M3×6	8
	10 mm Spacer	4
Landing Tube Mount	M3×25	4
	M3 Nut	4

Tools You'll Need

- Allen hex key set
- Nose Player

Step By Step Assembly

Step 1:

The 16mm diameter, 294mm length carbon fiber tube is affixed to the motor mount using an M3 x 35mm long screw.

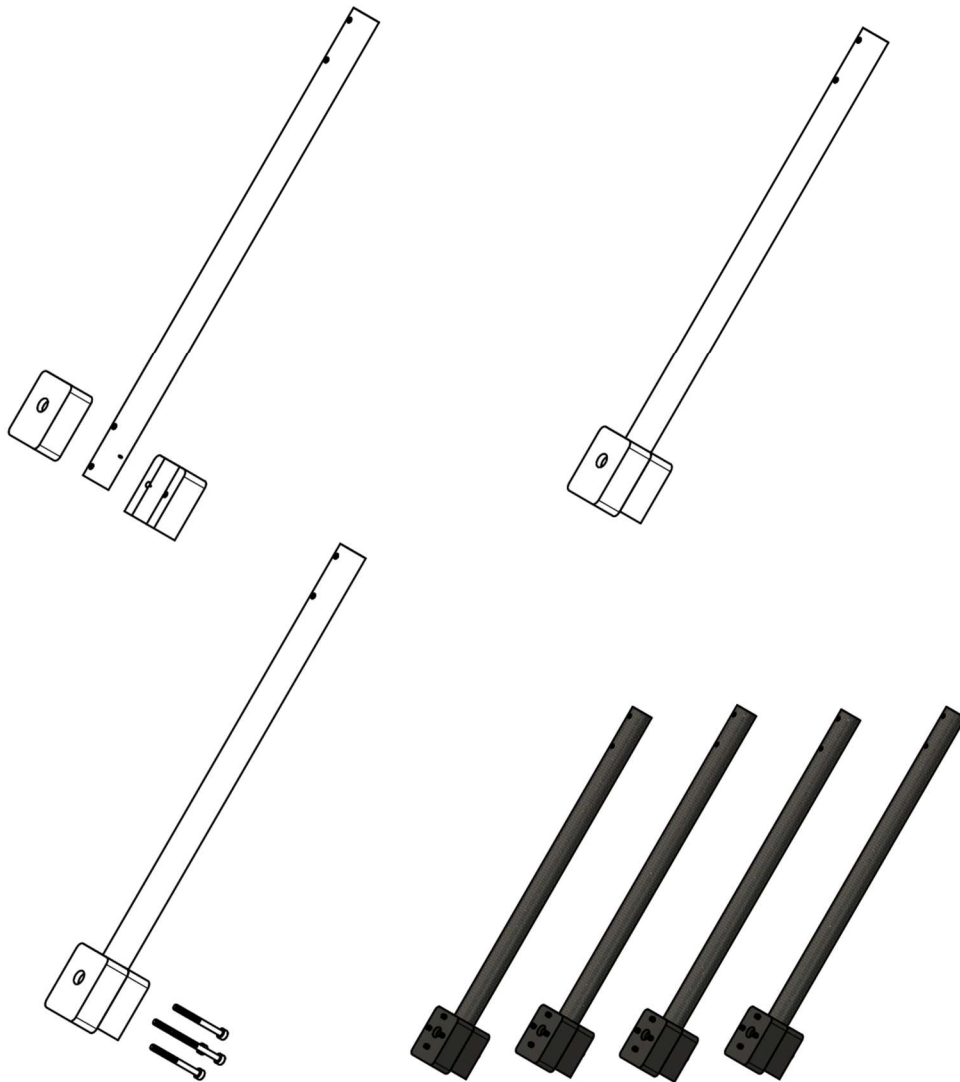

Step 2:

The bottom panel, made from a 2mm carbon fiber sheet, is securely connected to the motor-mounted carbon fiber tube arm using an M3 x 40mm long screw. This assembly is further tightened with an M3 nylon insert self-locking nut to ensure a firm and vibration-resistant connection.

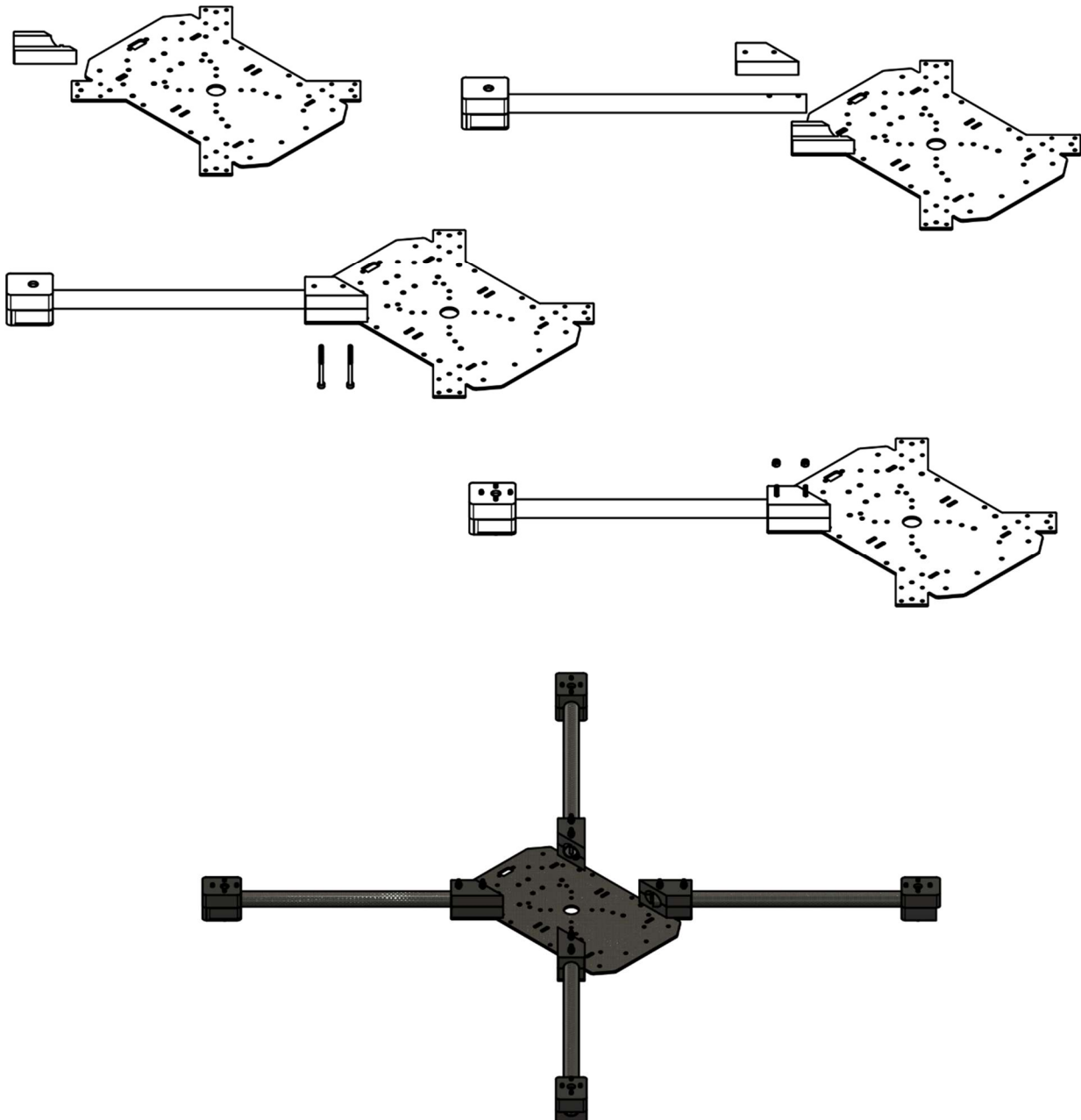

Step 3:

10mm Long M3 Standoff fixed on center of the bottom panel (carbon fiber sheet) of axl 30 using the 6mm long M3 screw. Then mount the FC mount panel in the standoff using same screw. The camera mount fixed on the front of the bottom panel using the 10mm long M3 screw and nut.

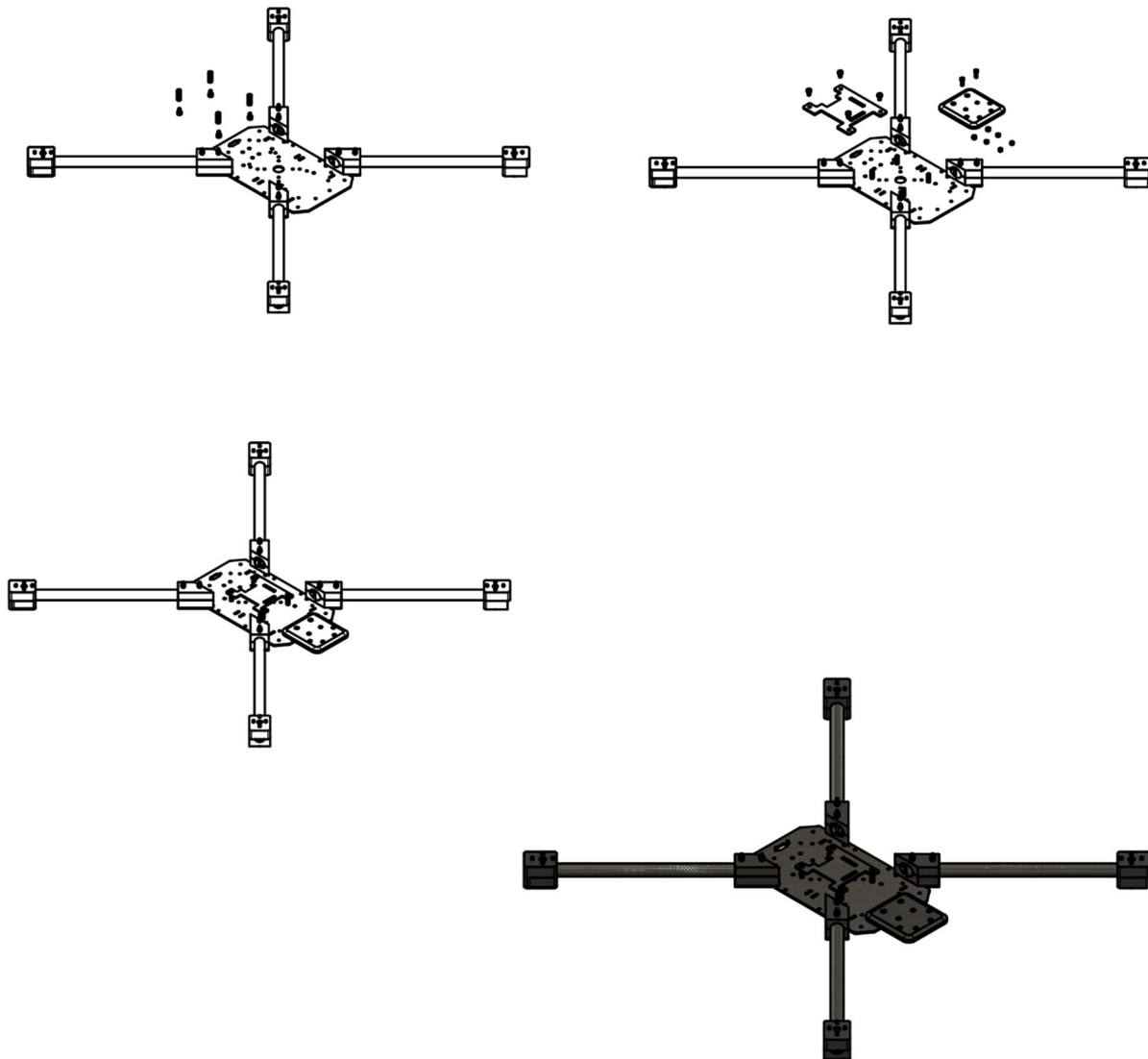

Step 4:

The 10mm long aluminum spacers are securely attached to the bottom side of the bottom panel (carbon fiber sheet) using 6mm long M3 Allen head screws. These spacers are then mounted onto the battery mount panel, which is a 2mm thick carbon fiber sheet, and tightened with 6mm long M3 screws.

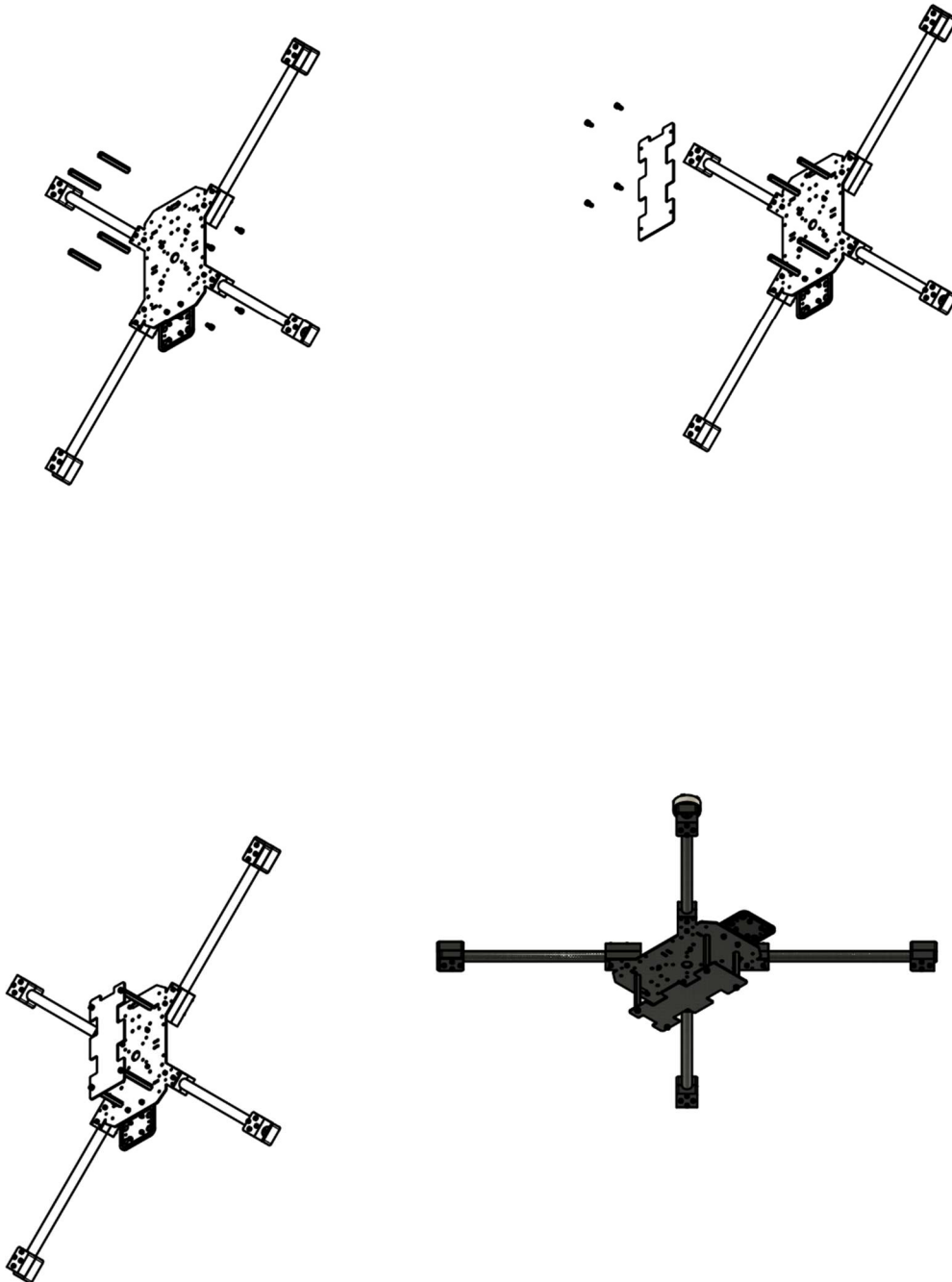

Step 5:

The 100mm long rod is inserted into the foot, establishing a secure connection with the leg mount. This assembly is then tightened using a 25mm long M3 Allen bolt and nut to ensure a firm and stable attachment.

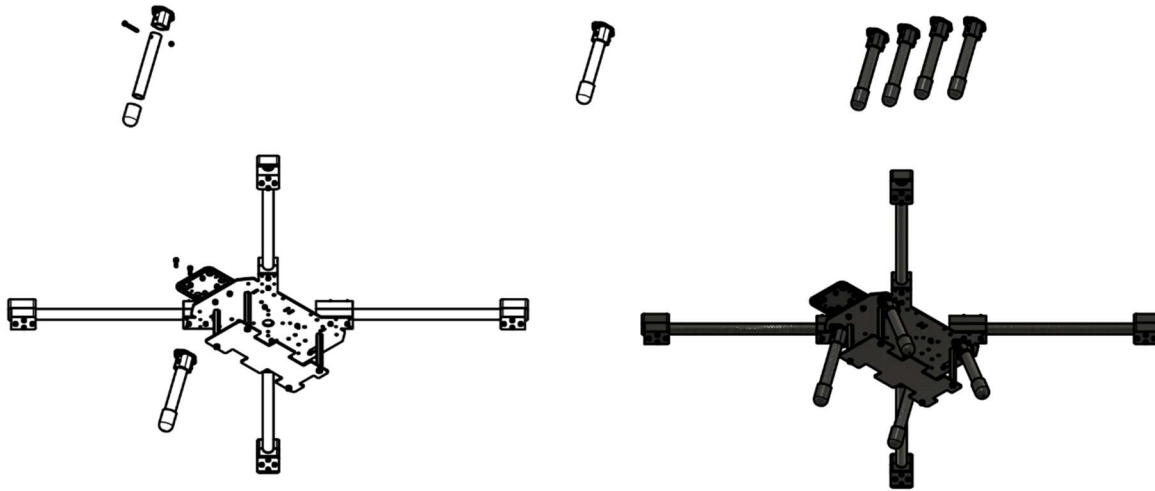

The landing gear is attached to the bottom panel using a 10mm long M3 Allen bolt and nut.

Step 6:

The 2mm thick carbon fiber top panel is affixed to the protruding screw of the arm mount and secured with a M3 selflock nut.

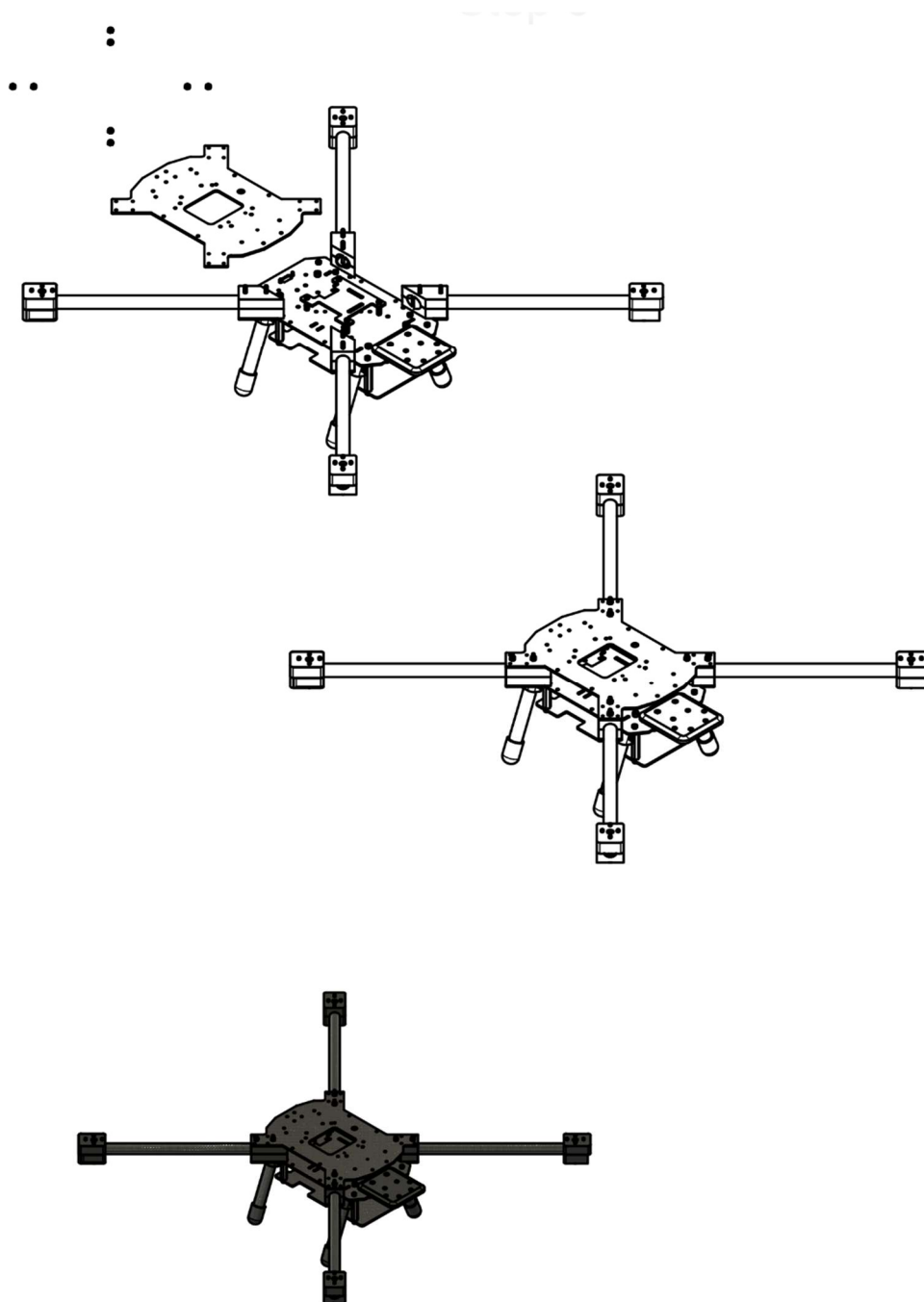

Specifications

Parameter	Value
Material	Carbon Fiber, Hyper ABS
Frame Weight	~500 g
Frame Size (L × W × H)	509 x 509 x 147 mm (L X W X H)
Max load capacity of the frame	2500 g

Key Features

High strength-to-weight carbon fiber construction

Offers exceptional structural integrity while keeping the frame ultra-light—resulting in nimble, responsive flight and better energy efficiency

Lightweight

Enhances maneuverability, reduces power draw, and extends overall flight endurance

Compact dimensions (509 x 509 x 147 mm)

Enables precise navigation without compromising on payload capability

Rugged durability

Carbon fiber frame resists impacts and harsh outdoor conditions, offering long-term reliability and fewer repair costs

DIY customization support

Designed for hands-on assembly and flexible upgrades, allowing users to tailor the frame to various applications.

Optimized for longevity

Precision-engineered components with performance and lifespan in mind ensure stable, long-lasting flight experiences

Storage & Maintenance

- Store frame parts in a cool, dry place, away from direct sunlight, heat, or heavy objects to prevent warping, resin breakdown, or mechanical stress.
- For cleaning, remove loose dirt with a dry soft brush or canned air; use isopropyl alcohol (70–90%) on a lint-free cloth to gently clean stubborn grime—avoid water or harsh chemicals—and ensure all components are completely dry before reassembly.

Safety Guidelines

- **Wear protective gear** during assembly—especially when handling carbon fiber and ABS components. Use gloves and eye protection to prevent injury from sharp edges or splinters.
- **Beware carbon fiber dust:** If cutting or drilling frame parts, do so in a well-ventilated area or use dust collection systems and wear a respiratory mask (HEPA-rated) to avoid inhalation
- **Verify fasteners:** Make sure all M3 screws, nuts, and standoffs are properly tightened. Use thread locker to prevent loosening due to vibration.

Visit Our website



Feel free to connect



Kakkanad, Ernakulam,
Kerala, India – 682030
P : +91 484 299 3399,
+91 949 771 7654
E : info@axldrone.com

C5 UL Cyber Park,
Special Economic Zone
Calicut, India – 673016
P : +91 9645 426 414
E : info@axldrone.com

1441 Broadway,
#5, New York, NY 10018
P : +(646) 260-6311
E : info@axldrone.com